

Model CP10 151



- End Of The Line Packaging System
- Servo Driven Upstacking System
- Funnel Guided Product Loading
- PLC Controlled Lubrication
- Small Machine Footprint



Product Infeed

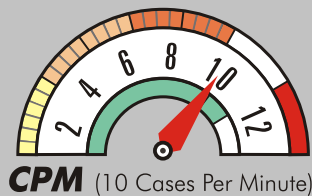

Product Upstacking

MANUFACTURER OF PACKAGING
AND AUTOMATED EQUIPMENT
www.zautomation.com



Z Automation Company, Inc.



CASE PACKER

CP15-10I - CASE PACKER SPECS

Rated Speed Interval (Min - Max)	10 Cases Per Minute
Product Feed	Infeed Conveyor
Frame Construction	Stainless Steel
Machine Width	5.5 ft
Machine Length	10 ft
Aprox. Machine Weight	4,000 lb
Product Pick-Off Vacuum	PIAB 100
Settings	Scales, Position Indicator
Lubrication	Cluster (Grease), PLC Controlled (OIL)
Compression	Plowing
Case Closing	"Dekka" Tape Head
Main Drive	Allen Bradley Servo Motor
Zero Access Guarding	1/4" Lexan
PLC Controller	Allen Bradley ControlLogix
Servo Drives	AB Kinetix
Supply Voltage	240 Volt, 3 Phase, 60 Hertz
Air Supply	6 -18 CFM @ 80 PSI
NEMA Rating	12
Operator interface	AB 5" Color Touch Screen Monochrome

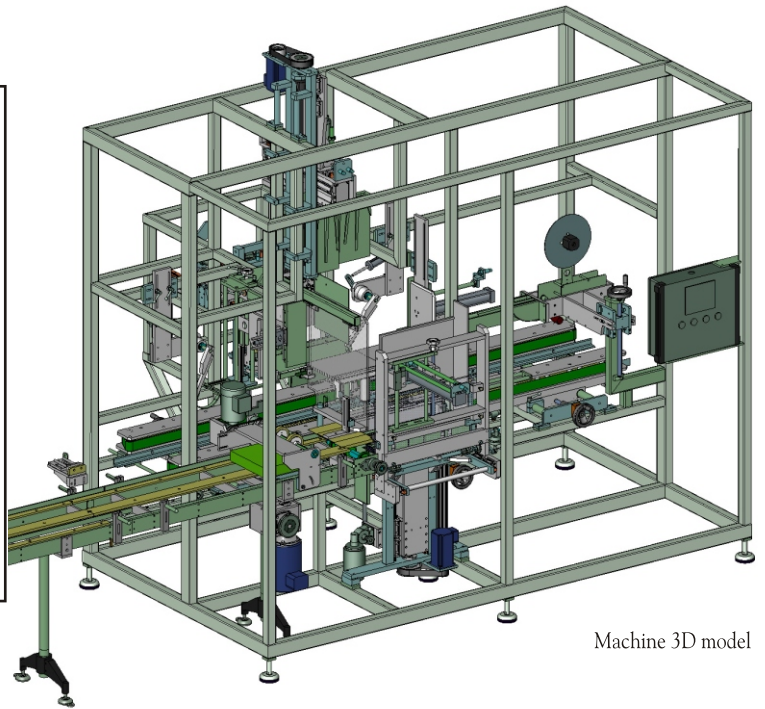

Machine 3D model

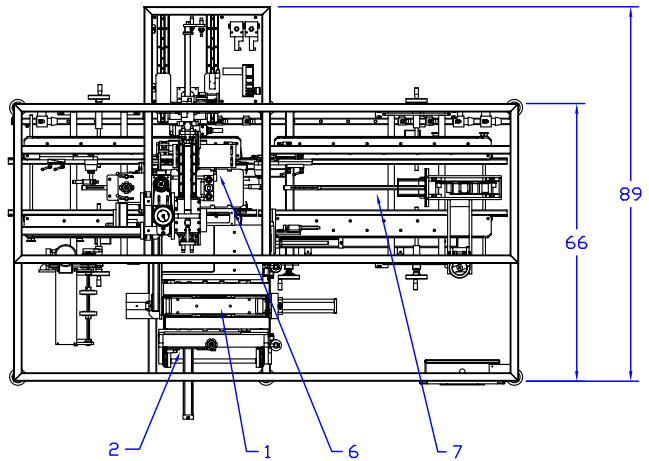

Machine floorplan

1. PRODUCT STACKER
2. MAIN PUSHER
3. SIDE PUSHER
4. VERTICAL GRIPPER
5. HORIZONTAL GRIPPER
6. LOADING AREA
7. CLOSING SECTION

